



Pallet Trucks

T14 – T20

Capacity 1.4 t – 2.0 t | Series 1155

PB

ION

PIEK*

Compact transport helper

- Compact design for fast, easy manoeuvring in confined spaces
- Low steering effort for reduced fatigue during physically demanding tasks
- Robust chassis and reinforced forks for transporting loads of up to two tonnes
- T14 and T16 compact models for operation in confined spaces e.g. city centre deliveries

* PIEK certified. Low noise pollution, max. 60 dB(A)

TECHNICAL DATA (according to VDI 2198)

			LINDE MH	LINDE MH	LINDE MH	LINDE MH	
Characteristics	1.1	Manufacturer (abbreviation)	LINDE MH	LINDE MH	LINDE MH	LINDE MH	
	1.2	Manufacturer's type designation	T14	T16	T18	T20	
	1.2a	Series	1155	1155	1155	1155	
	1.3	Drive	Battery	Battery	Battery	Battery	
	1.4	Operation	Pedestrian	Pedestrian	Pedestrian	Pedestrian	
	1.5	Rated capacity/rated load	Q (t)	1.4	1.6	1.8	2.0
	1.6	Load centre distance	c (mm)	600	600	600	600
	1.8	Load distance, centre of drive axle to fork	x (mm)	893/965 ¹²⁾	893/965 ¹²⁾	893/965 ¹²⁾	893/965 ¹²⁾
	1.9	Wheelbase	y (mm)	1160/1232 ¹²⁾	1230/1302 ¹²⁾	1230/1302 ¹²⁾	1305/1377 ¹²⁾
Weight	2.1	Service weight	kg	329 ³⁾	412 ³⁾	412 ³⁾	501 ³⁾
	2.2	Axle loading, laden front/rear	kg	610/1119 ³⁾	698/1314 ³⁾	746/1466 ³⁾	839/1662 ³⁾
	2.3	Axle loading, unladen front/rear	kg	256/73 ³⁾	317/95 ³⁾	317/95 ³⁾	390/111 ³⁾
Tyres/chassis	3.1	Tyres: solid rubber, superelastic, pneumatic, polyurethane		Polyurethane	Polyurethane	Polyurethane	Polyurethane
	3.2	Tyre size, front		Ø 230 × 75	Ø 230 × 75	Ø 230 × 75	Ø 230 × 75
	3.3	Tyre size, rear		Ø 85 × 105 (Ø 85 × 100) ⁴⁾	Ø 85 × 105 (Ø 85 × 100) ⁴⁾	Ø 85 × 105 (Ø 85 × 100) ⁴⁾	Ø 85 × 105 (Ø 85 × 100) ⁴⁾
	3.4	Additional wheels (dimensions)		2x Ø 125 × 40	2x Ø 125 × 40	2x Ø 125 × 40	2x Ø 125 × 40
	3.5	Wheels, number front/rear (x = driven wheels)		1x + 2/2 (1x + 2/4) ⁴⁾	1x + 2/2 (1x + 2/4) ⁴⁾	1x + 2/2 (1x + 2/4) ⁴⁾	1x + 2/2 (1x + 2/4) ⁴⁾
	3.6	Tread, front	b10 (mm)	482 ²⁾	482 ²⁾	482 ²⁾	482 ²⁾
	3.7	Tread, rear	b11 (mm)	355/375 [395/515] ²⁾	355/375 [395/515] ²⁾	355/375 [395/515] ²⁾	355/375 [395/515] ²⁾
Dimensions	4.4	Lift	h3 (mm)	125 ²⁾	125 ²⁾	125 ²⁾	125 ²⁾
	4.9	Height drawbar in driving position min./max.	h14 (mm)	810/1205 ²⁾	810/1205 ²⁾	810/1205 ²⁾	810/1205 ²⁾
	4.15	Height, lowered	h13 (mm)	86 ⁵⁾	86 ⁵⁾	86 ⁵⁾	86 ⁵⁾
	4.19	Overall length	l1 (mm)	1579 ²⁾	1649 ²⁾	1649 ²⁾	1719 ²⁾
	4.20	Length to fork face	l2 (mm)	429 ²⁾	499 ²⁾	499 ²⁾	569 ²⁾
	4.21	Overall width	b1/b2 (mm)	720 ²⁾	720 ²⁾	720 ²⁾	720 ²⁾
	4.22	Fork dimensions DIN ISO 2331	s/e/l (mm)	55/165/1150	55/165/1150	55/165/1150	55/165/1150
	4.25	Fork spread	b5 (mm)	520/540 [560/680] ²⁾	520/540 [560/680] ²⁾	520/540 [560/680] ²⁾	520/540 [560/680] ²⁾
	4.32	Ground clearance, centre of wheelbase	m2 (mm)	32/157 ²⁾	32/157 ²⁾	32/157 ²⁾	32/157 ²⁾
	4.33	Load dimension b12 × l6	b12 × l6 (mm)	1200 × 800	1200 × 800	1200 × 800	1200 × 800
	4.34	Aisle width predetermined load dimensions	Ast (mm)	2172 ⁸⁾	2245 ⁸⁾	2245 ⁸⁾	2317 ⁸⁾
	4.34.1	Aisle width for pallets 1000 × 1200 crossways	Ast (mm)	2174 ⁸⁾ 9)10)	2247 ⁸⁾ 9)10)	2247 ⁸⁾ 9)10)	2319 ⁸⁾ 9)10)
	4.34.2	Aisle width for pallets 800 × 1200 lengthways	Ast (mm)	2069 ⁸⁾ 9)	2142 ⁸⁾ 9)	2142 ⁸⁾ 9)	2214 ⁸⁾ 9)
4.35	Turning radius	Wa (mm)	1365/1437 ⁹⁾	1438/1510 ⁹⁾	1438/1510 ⁹⁾	1510/1582 ⁹⁾	
Performance	5.1	Travel speed, laden/unladen	km/h	6/6 ¹¹⁾	6/6 ¹¹⁾	6/6 ¹¹⁾	6/6 ¹¹⁾
	5.2	Lifting speed, laden/unladen	m/s	0.035/0.047 ³⁾	0.035/0.046 ³⁾	0.031/0.046 ³⁾	0.033/0.042 ³⁾
	5.3	Lowering speed, laden/unladen	m/s	0.064/0.027 ³⁾	0.07/0.028 ³⁾	0.073/0.028 ³⁾	0.069/0.035 ³⁾
	5.8	Max. gradeability, laden/unladen	%	13.0/20.0	10.0/20.0	9.0/20.0	9.0/20.0
	5.9	Acceleration time, laden/unladen	s	7.0/6.6	6.9/6.4	6.9/6.4	7.1/6.4
	5.10	Service brake		Electric-engine	Electric-engine	Electric-engine	Electric-engine
Electric-engine	6.1	Drive motor rating S2 60 min	kW	1.1	1.3	1.3	1.3
	6.2	Lift motor rating at S3 15%	kW	1.0	1.0	1.0	1.2
	6.3	Battery according to DIN 43531/35/36 A, B, C, no		Li-ION compact	2 PzS-B	2 PzS-B	43 535 B/2 PzS
	6.4	Battery voltage/nominal capacity K5	(V)/(Ah) or kWh	24/62 (125) ¹²⁾	24/150	24/150	24/250
	6.5	Battery weight (±5%)	kg	15/22 ⁶⁾	134/154 ⁶⁾	134/154 ⁶⁾	163/250 ⁶⁾
	6.6	Energy consumption according to DIN EN 16796	kWh/h	0.27	0.26	0.26	0.3
	6.6.1	CO2 equivalent according to DIN EN 16796	(kg/h)	0.15	0.14	0.14	0.16
	6.7	Turnover output according to VDI 2198	t/h	77.0	90.0	101.0	110.0
6.8	Turnover efficiency according to VDI 2198	t/kWh	129	145	163	176	
Drive/lifting mechanism	8.1	Type of drive unit		AC control	AC control	AC control	AC control
Additional data	10.7	Sound pressure level LpAZ (at the operator's seat)	dB (A)	57 ¹³⁾	63 ¹³⁾	63 ¹³⁾	63 ¹³⁾

1) Forks raised/lowered

2) (±5 mm)

3) (± 10%)

4) Figures in parenthesis with tandem load wheels

5) (-0/+5 mm)

6) Min./max.

7) (±2 mm)

8) Including a 200 mm (min.) operating aisle clearance

9) With creep speed = tiller in vertical position

10) With fork length 1150 mm

11) (± 5%)

12) (Option)

13) (± 2.5)

T14, T16

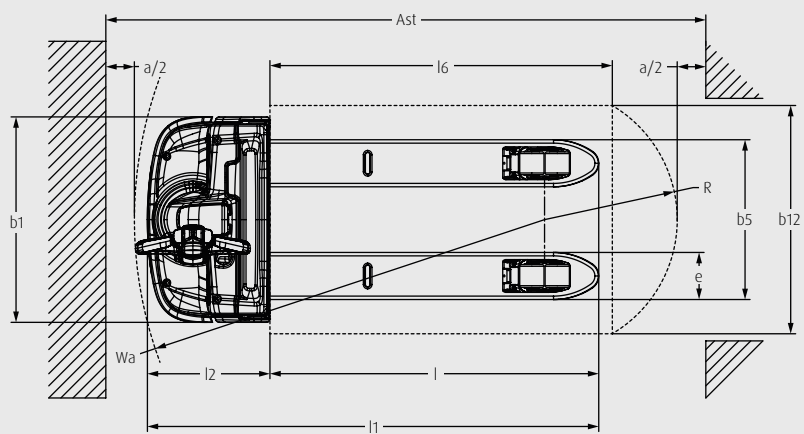
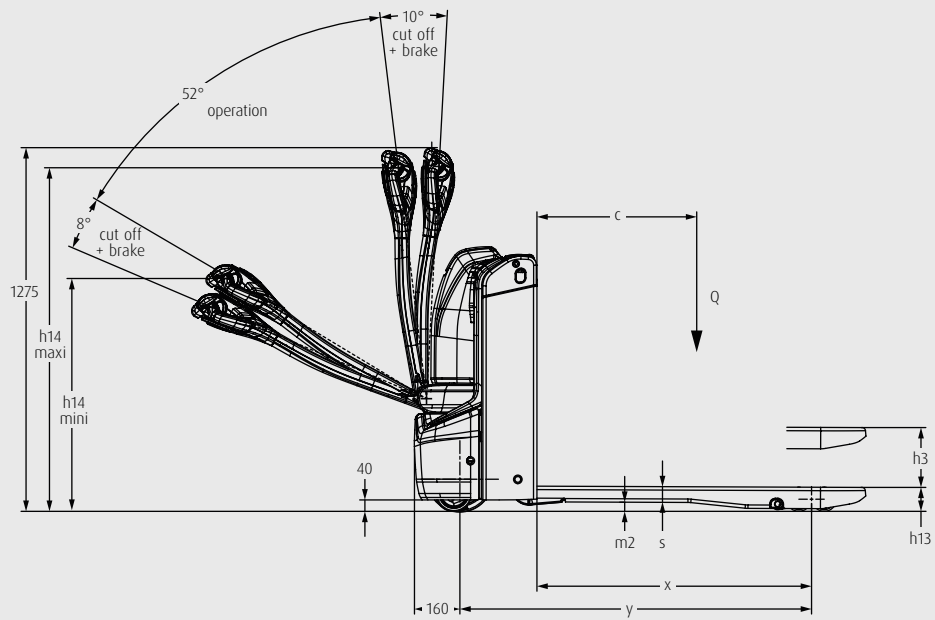

T16, T18, T20

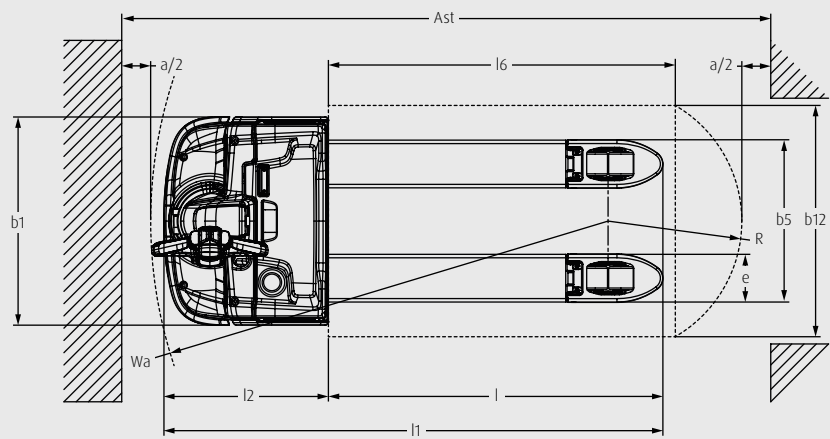
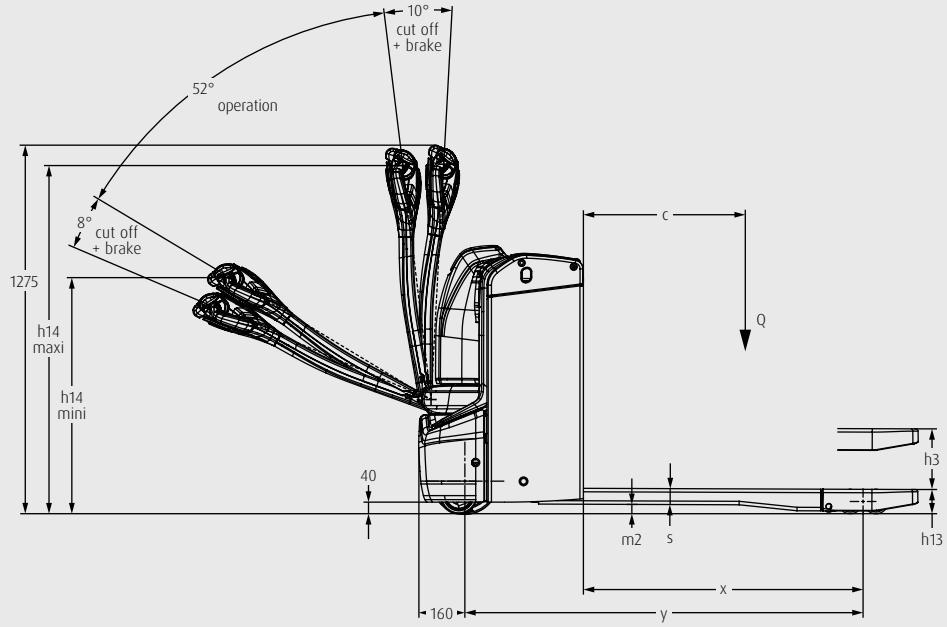

STANDARD AND OPTIONAL EQUIPMENT

Manufacturer's type designation/equipment		T14	T16	T18	T20
Safety	Active foot bumper – assistant system for foot protection system	○	○	○	○
	Long tiller and low chassis skirt	●	●	●	●
	Automatic speed reduction when cornering	●	●	●	●
	Easily accessible emergency stop button	●	●	●	●
	Buzzer – for operation in low noise areas	●	●	●	●
	Horn – for operation in noisy environments	○	○	○	○
	Key switch	●	●	●	●
	Log in PIN code	○	○	○	○
Service	CAN bus technology	●	●	●	●
Digitalisation	Data transmission online	○	○	○	○
	Data transmission WIFI	○	○	○	○
	Linde connect:desk – local fleet management with different functional modules	○	○	○	○
	Linde connect:cloud – fleet management as a service (hosted version)	○	○	○	○
	Pre-shift check – allows operator to report truck condition before use	○	○	○	○
Operation/load handling	Proportional speed – speed depending on tiller angle	○	●	●	●
	Creep speed – for operation with tiller in vertical position	○	○	○	○
	Multifunction display – hour meter, maintenance indication, battery discharge indicator and internal fault code indication	●	●	●	●
	Ergonomic tiller head with easy access to all controls	●	●	●	●
	Load backrest h = 1800 mm	○	○	○	○
	Accessory support	○	○	○	○
	Support for clipboard and scanner	○	○	○	○
	Metal battery cover	○	○	○	○
Environment	Coldstore protection to -35 °C (in/out)	○	○	○	○
Attachment/forks	Width over forks: 520 mm, 540 mm, 560 mm, 680 mm	○	○	○	○
	Fork length: 1000 mm, 1150 mm with overhang 188 mm	○	○	○	○
	Fork length: 1600 mm with overhang 188 mm, 2400 mm with overhang 563 mm	–	○	○	○
	Fork marking – easy handling of crosswise pallets	●	○	–	–
Axles and tyres	Drive wheels: standard duty	●	●	●	●
	Drive wheel: heavy duty, high grip	○	○	○	○
	Single load wheels: polyurethane	●	●	●	●
	Tandem load wheels: polyurethane	○	○	○	○
	Single load wheels: polyurethane greasable	○	○	○	○
	Tandem load wheels: polyurethane greasable	○	○	○	○
	Triple load wheels: polyurethane	○	○	–	–
	Auto-adjustable castor wheels	○	○	○	○
Drive and brake system	Maintenance-free AC motor	●	●	●	●
	Electromagnetic braking system	●	●	●	●
	Li-ION batteries – different battery capacities depending on model with front, laterally or vertically mounted opportunity charging plug	●	○	○	○
	Lead-acid batteries	–	○	○	○
	Battery compartment for compact battery, vertical change	●	○	–	–
	Battery compartment for 2 PzS BS battery	–	○	○	–
	Battery compartment for 2 PzS battery, lateral or vertical change	–	○	○	○
	On-board charger for lead-acid and Li-ION batteries	○	○	○	○
External chargers	○	○	○	○	

● Standard equipment ○ Optional equipment – Not available

CHARACTERISTICS



Long tiller and low mounted chassis

Safety

- Long tiller arm ensures operator is at a safe distance from the truck
- Low chassis skirt and optional active bumper prevent foot injuries
- Automatic electromagnetic brake and belly switch for reduced accident risk
- Automatic parking brake holds truck securely on loading ramps or inclines



Shaped tiller head with intuitive controls

Ergonomics

- Ergonomic tiller head with easily accessible controls
- Easy to operate with one hand, even when wearing gloves
- Multifunction display shows all important truck information
- Generous storage for rolls of shrink-wrap, clipboard or scanner



Compact chassis

Handling

- Compact chassis and small turning circle for optimum manoeuvrability in tight spaces
- Creep speed option for precise handling in tight spaces
- Booster function for short-term increase in power
- Optional compact Li-ION battery (for T14 and T16) for additional manoeuvrability



Easy access to internal components

Service

- Robust AC motor for long maintenance intervals and lower operating costs
- Low-wear components for long service life and high availability
- Easy-to-reach service components for fast, efficient maintenance and repair
- CAN bus architecture for easy access to all truck data
- Optional data transmission unit for remote diagnostics and software updates

Subject to modification in the interest of progress. Illustrations and technical specifications could include options and are not binding for actual constructions. All dimensions subject to usual tolerances.

Presented by:

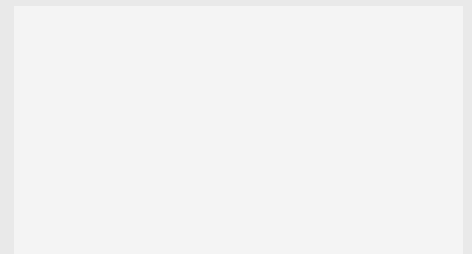

Linde Material Handling GmbH

Carl-von-Linde-Platz | 63743 Aschaffenburg | Germany
Phone + 49 6021 99 0 | Fax + 49 6021 99 1570
www.linde-mh.com | info@linde-mh.com

Printed in Germany | DS_T14-T20_1155_en_C_0624